

S3CMOS Series USB3.0 - 23.2mm Eyepiece CMOS Camera

ToupTek S3CMOS is an economic version with simple and compact structure USB3.0 CMOS eyepiece camera. So here, the S means simple and compact. USB3.0 is used as the data transfer interface.

Microscope eyepiece camera with 23.2 diameter and compact size;

The S3CMOS eyepiece camera comes with high-speed USB3.0 interface and high frame rate video display keep the screen smooth without interruption;

Also the S3CMOS comes with advanced video & image processing application ToupView;

The S3CMOS can be widely used to transfer the mono or binocular student microscopes to digital microscope.

With 23.2 to 30 mm or 23.2 to 30.75 convert ring, the S3CMOS camera can also change the stereo microscope to digital stereo microscope.

- Microscope eyepiece camera with 23.2 diameter and compact size;
- Easy to extend to C or CS- Mount camera with high quality lens(optional);
- High-quality camera with Aptina CMOS sensor;
- Auto white balance and auto-exposure; Brightness, contrast, chroma, and saturation can be adjusted;
- High-speed USB3.0 interface and high frame rate video display keep the screen smooth without interruption;
- With advanced video & image processing application ToupView;
- Custom programmable with SDK provided;



| Order Code | Sensor & Size | Pixel(μm) | G Responsivity Dynamic range SNRmax | FPS/Resolution | Binning | Exposure |
|--|--------------------------------------|-----------|---|--|-------------------|-------------|
| S3CMOS05100KPA TP305100A(New) 06/05/2020 | 5.1M/IMX335(C) 1/2.8" (5.18x3.89) | 2.0x2.0 | 505mV 70dB 43dB | 20@2592x1944 20@1280x960 20@640x480 | 1x1 1x1 1x1 | 0.1-2000 ms |
| S3CMOS05000KPA TP305000A | 5.0M/MT9P001(C) 1/2.5"(5.70x4.28) | 2.2x2.2 | 0.53 V/lux-sec 66.5dB 40.5dB | 15@2560x1920 15@2048x1536 30@1920x1080 | 1x1 2x2 | Auto |
| S3CMOS05000KPC TP305000C | 5.0M/SC5033(C) 1/2.7"(5.18x3.89) | 2.0x2.0 | 2 V/lux-sec 64dB 35dB | 15@2592x1944 20@2048x1536 20@1600x1200 30@800x600 | 1x1 2x2 | Auto |

C: Color; M: Monochrome;

| Other Specification for S3CMOS Camera | |
|---------------------------------------|--|
| Spectral Range | 380-650nm (with IR-cut Filter) |
| White Balance | Auto White Balance |
| Color Technique | N/A |
| Capture/Control SDK | Windows/Linux/macOS/Android Multiple Platform SDK(Native C/C++, C#/VB.NET, Python, Java, DirectShow, Twain, etc) |
| Recording System | Still Picture and Movie |
| Cooling System* | Natural |
| Operating Environment | |
| Operating Temperature(in Centidegree) | -10~ 50 |
| Storage Temperature(in Centidegree) | -20~ 60 |
| Operating Humidity | 30~80%RH |
| Storage Humidity | 10~60%RH |
| Power Supply | DC 5V over PC USB3.0 Port |
| Software Environment | |
| Operating System | Microsoft® Windows® XP / Vista / 7 / 8 /10 (32 & 64 bit) OSx(Mac OS X) Linux |
| PC Requirements | CPU: Equal to Intel Core2 2.8GHz or Higher |
| | Memory:2GB or More |
| | USB Port:USB3.0 High-speed Port |
| | Display:17" or Larger |
| | CD-ROM |

Dimension of S3CMOS Series Camera

Installation drawings. The S3CMOS Camera body, made from aluminum alloy blackening, ocular ousing: Dia.32 X 56mm ensures a heavy duty, workhorse solution. The camera is designed with a high quality IR-CUT filter to filter the infrared light and protect the camera sensor. No moving parts included. These measures ensure a rugged, robust solution with an increased lifespan when compared to other industrial camera solutions.

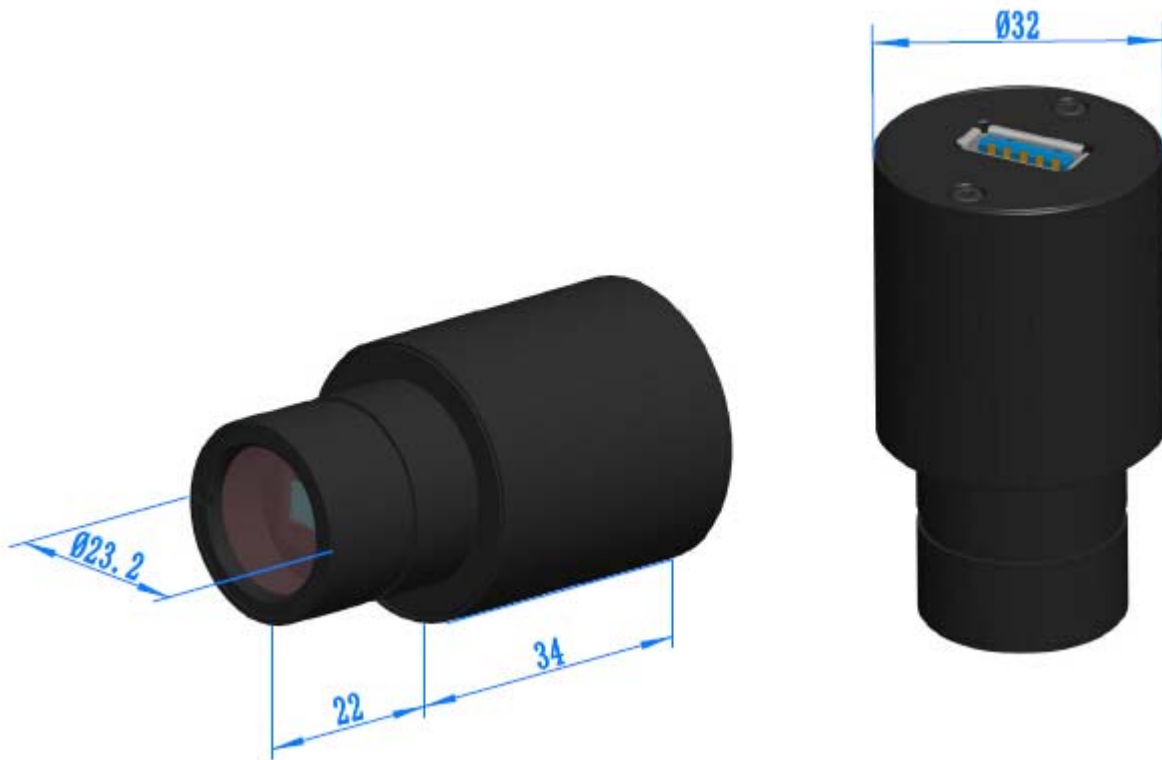

Dimension of S3CMOS Series Camera

Packing Information of S3CMOS Series Camera



| Standard Camera Packing List | |
|------------------------------|--|
| A | Carton L:52cm W:32cm H:33cm (50pcs, 12~17Kg/ carton), not shown in the photo |
| B | Gift box L:15cm W:15cm H:10.0cm (0.25~0.35Kg/ box) |

| | | |
|--------------------|--|--|
| C | S3CMOS series camera | |
| D | High-Speed USB3.0 A male to mini B 5-pin male gold-plated connectors cable /1.5m | |
| E | CD (Driver & utilities software, Ø8cm) | |
| Optional Accessory | | |
| F | C-Mount Adapter Housing:108027(HS502) | |
| G | 108015(Dia.23.2mm to 30.0mm Ring)/Adaptor rings for 30mm eyepiece tube | |
| H | 108016(Dia.23.2mm to 30.5mm Ring)/ Adaptor rings for 30.5mm eyepiece tube | |
| I | 108017(Dia.23.2mm to 31.75mm Ring)/ Adaptor rings for 31.75mm eyepiece tube | |
| J | Calibration Kit | 106011/TS-M1(X=0.01mm/100Div.); 106012/TS-M2(X,Y=0.01mm/100Div.); 106013/TS-M7(X=0.01mm/100Div., 0.10mm/100Div.) |

The above statements are based on our present knowledge. Our statements should not be interpreted as a guarantee of characteristics. The use of our products by our customers is subject to different conditions, therefore none of our customers are relieved of the responsibility of testing our products by themselves. A liability for consequential damage will not be accepted in any case. For damage resulting from the use of this information we can only be held responsible if there is evidence of malice or negligence on our part. This data-sheet replaces any previous data sheets.

ASMETEC, METODRILL, METOCHECK, METOLIGHT, METOCLEAN and METO are registered trade marks of ASMETEC GmbH.
USB-Cam-S3CMOS-DB-E.doc, version Feb-21